

2. Replacing the Transport Rollers

As the rollers start to wear out, feeding quality declines, and document feed errors, such as paper jams, become more likely. If document feed errors continue to occur after cleaning the rollers, purchase the Roller Replacement Kit and replace the transport rollers (pickup, feed, and retard rollers).

Roller Replacement Cycle

The feeding rollers are consumables that must be replaced after feeding about every 250,000 pages.

When the rollers have fed more than 250,000 pages, a roller replacement message appears on the display panel whenever the scanner is turned ON. When the scanner is configured to reboot with the computer, a roller replacement message also appears on the computer screen.

R e p l a c e R o l l e r

! IMPORTANT

- When the roller replacement message appears, purchase the Roller Replacement Kit and replace the rollers by following the relevant steps in the removing and reinstalling procedures.
 - (See “Removing and Reinstalling the Pickup Roller” on p. 41.)
 - (See “Removing and Reinstalling the Feed Roller” on p. 42.)
 - (See “Removing and Reinstalling the Retard Roller” on p. 44.)
- When the rollers start to wear out, problems such as paper jams and document misfeeds may occur more frequently. If this happens, replace the rollers, regardless of the page count of the roller usage counter.
- Messages on the display panel can be cleared by pressing the Count Clear key. However, the messages will continue to be displayed each time the scanner is turned ON until the roller counter is reset.
- Make sure to reset the roller counter when replacing the rollers. (See “Checking and Resetting the Page Counter” on p. 39.)

Roller Replacement Kit

The Roller Replacement Kit consists of replacement pickup, feed, and retard rollers. For details, contact your local authorized Canon dealer or service representative.

Product Name: Roller Replacement Kit

Product Code: 4009B001

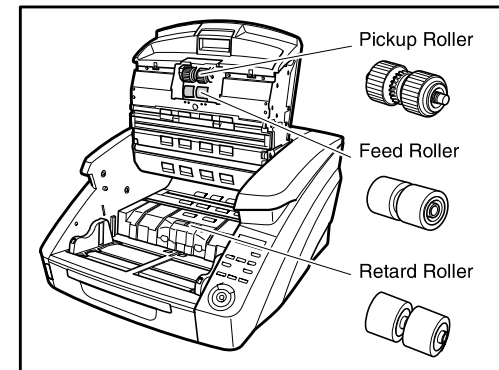

Checking and Resetting the Page Counter

The roller usage counter can be checked and reset using the Roller Counter in the User Mode setting.

! IMPORTANT

- This counter shows the number of pages transported by the currently installed feed rollers. Make sure to reset the counter when you replace the rollers.
- The Total Counter shows the total number of pages fed over the life of the scanner, and cannot be reset.

1. Press the Menu key on the control panel to activate the User Mode.

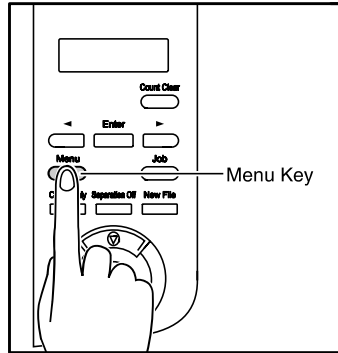

2. Press the [◀] key twice to display [Roller Counter].



3. Check the number of pages fed by the rollers, and press [Enter].

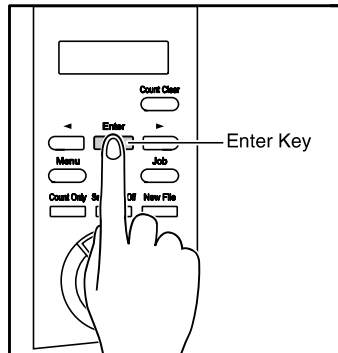

The counter reset mode is activated.



4. Press the [◀] key to select [RESET], and press [Enter].

The counter is reset to zero.



5. Press the [Stop] key to exit the User Mode.

Removing and Reinstalling the Rollers

Follow the procedure shown below to remove and reinstall the rollers when you need to clean or replace the Pickup, Feed, or Retard Rollers.

⚠ CAUTION

- Turn OFF the power switch, and disconnect the power plug from the power outlet when you remove or reinstall the rollers. Leaving the power turned ON may result in an electric shock.
- Do not place excessive force on the rollers when removing or reinstalling the rollers. Deformation of the rollers may cause feed errors.

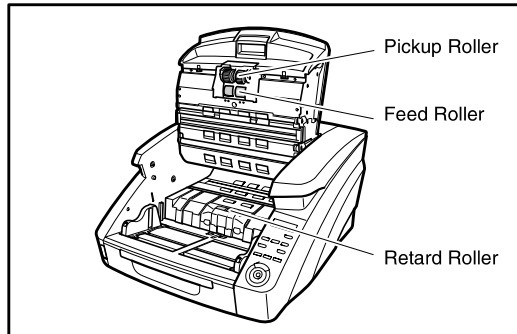

■ Removing and Reinstalling the Pickup Roller

1. Press the Open/Close button and carefully raise the upper unit until it stops.

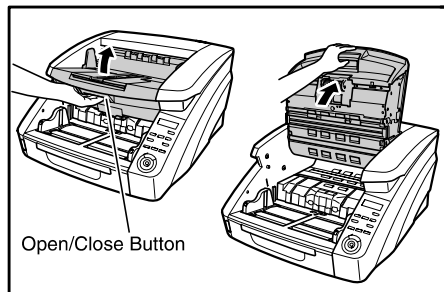

2. Open the roller cover.

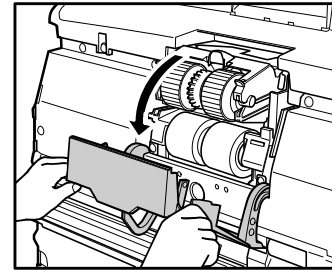

3. Open the roller holder.

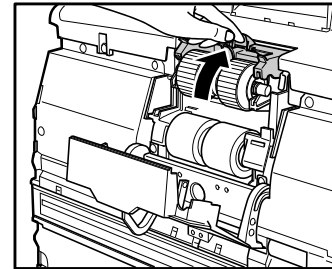

💡 Hint

The roller holder returns to its original position when released.

4. Remove the pickup roller.

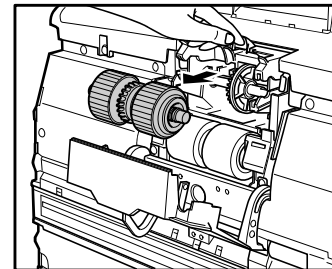

5. Open the roller holder, and insert the new pickup roller.

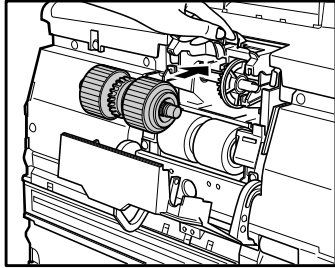

! IMPORTANT

Install the Pickup Roller so that side with the gear is on the left.

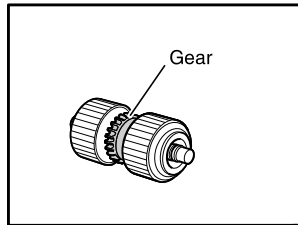

6. Close the roller cover. Check that it makes a latching sound and that it is securely returned to its original position.

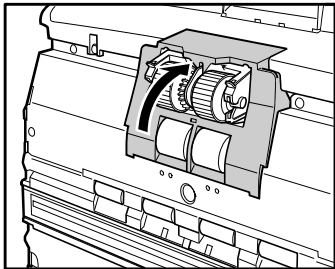

! IMPORTANT

Failure to firmly close the roller holder and roller cover may cause a feed error. Always be sure to check that the roller holder and roller cover are closed.

7. Gently lower the upper unit (①). Press down on both sides of the upper unit to ensure that it is securely closed (②).

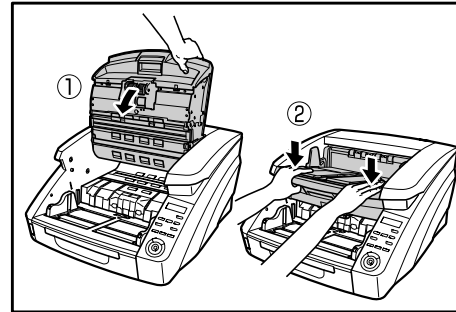

■ Removing and Reinstalling the Feed Roller

1. Press the Open/Close button and carefully raise the upper unit until it stops.

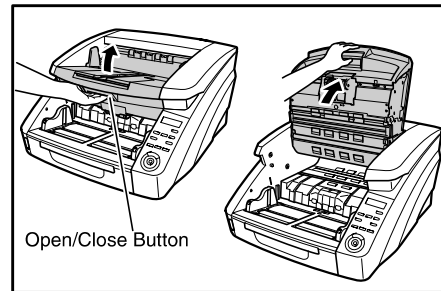

2. Open the roller cover.

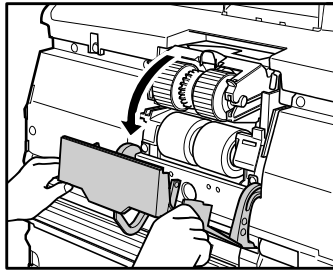

3. Pull the roller lock lever down.

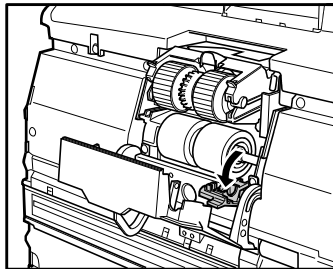

4. Slide the feed roller to the right, and then pull them towards you.

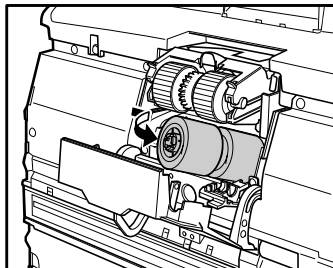

5. Remove the feed roller.

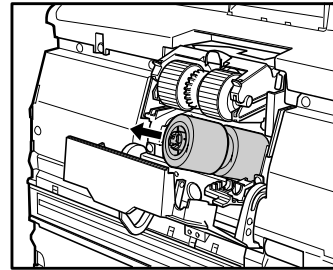

6. Place the new feed roller on the pin.

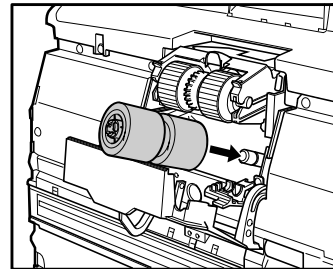

7. Put the feed roller in place (①), and align the notch in the roller's axle with the shaft on the scanner (②).

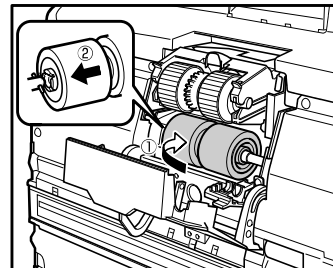

8. Push the roller lock lever up to lock the feed roller.

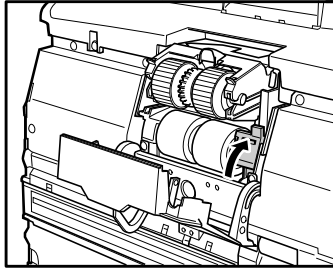

9. Close the roller cover. Check that it makes a latching sound and that it is securely returned to its original position.

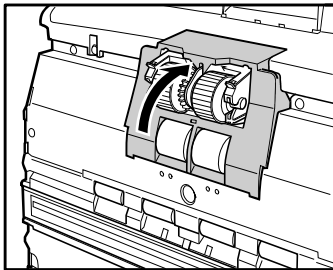

! IMPORTANT

Failure to firmly close the roller cover may cause a feed error.
Always be sure to check that the roller cover is closed.

10. Gently lower the upper unit (①). Press down on both sides of the upper unit to ensure that it is securely closed (②).

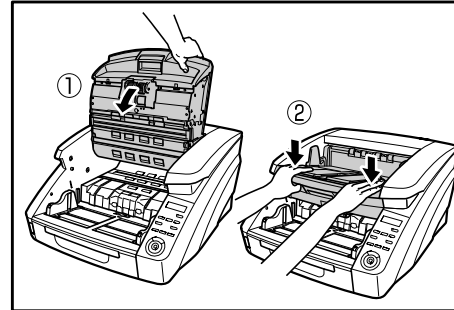

■ Removing and Reinstalling the Retard Roller

1. Press the Open/Close button and carefully raise the upper unit until it stops.

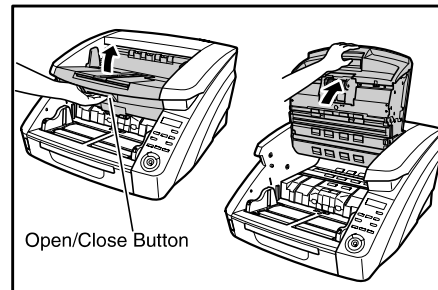

2. Grasp the roller cover with your fingers, and pull it up to remove it.

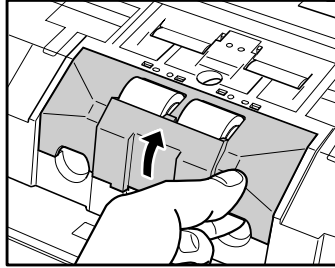

3. Push the roller lock lever up (①) and move it to the left (②) to unlock the roller.

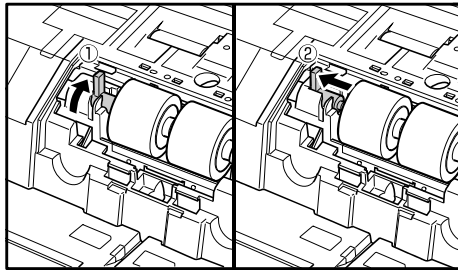

4. Remove the retard roller.

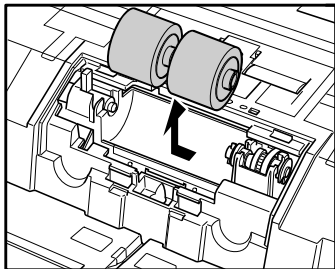

5. Set the retard roller into place in the scanner.

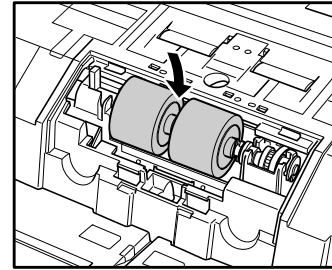

6. Align the notches in the roller with the shaft pins in the scanner, then slide the roller lock lever in the direction indicated by the arrow.

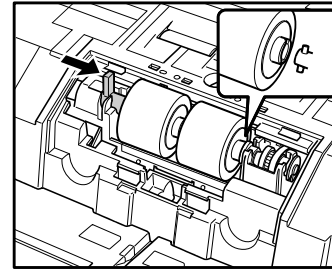

7. Pull the roller lock lever down to lock the retard roller in place.

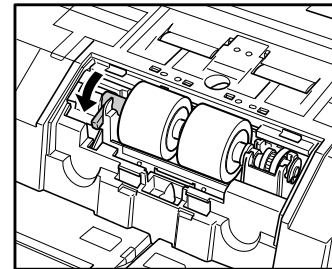

8. Replace the roller cover.

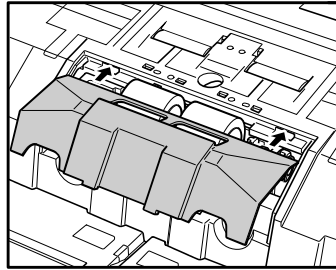

9. Push the front of the roller cover in. Check that it makes a latching sound and that it is securely returned to its original position.

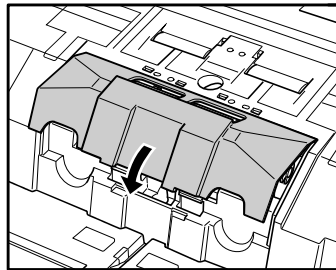

10. Gently lower the upper unit (①). Press down on both sides of the upper unit to ensure that it is securely closed (②).

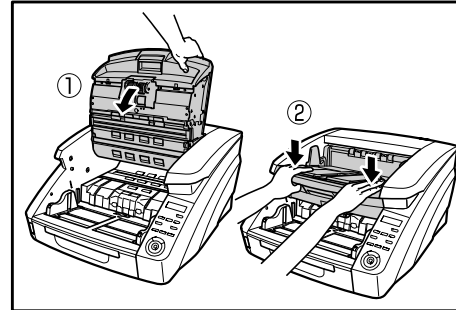

⚠ CAUTION

Make sure that the hook is completely latched and the roller cover is not loose. If the roller cover is loose, the Document Feed Tray will catch on it causing the scanner to malfunction.